

MRO Delay Line ICD

Delay Line to Beam Combining Facility

ICD INT-406-VEN-0009

The Cambridge Delay Line Team

rev 0.7

16 September 2010

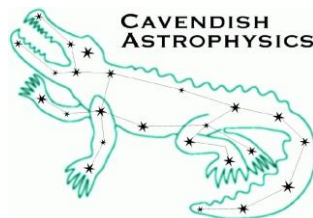

Cavendish Laboratory
JJ Thomson Avenue
Cambridge CB3 0HE
UK

1 ICD Description

Specific entry from the ICD N² Table contained in FDR document:

ICD Number	Sub-systems		Org	Owner	Brief description and preliminary contents
INT-406- VEN-0009	Delay line	BCF infrastructure (building)	MRAO	MF	Defines the mechanical and space envelope interfaces between the delay lines and the BCF (DLA and BCA areas). <ul style="list-style-type: none"> • Layout of delay line pipes and interface of supports to floor • Interface between delay line pipes and walls • Services requirements and placement of control racks

2 Change Record

Revision	Date	Authors	Changes
0.1	2007-08-10	MF	First draft version
0.2	2009-04-07	MF	Updated with most interface details
0.3	2009-04-28	MF	Revised Low latency cable and connectors Table 2 page 11 Revised end plate drawing – page 12 Revised datum switch connector and removed interface box – pages 7 and 12 Added anchor bolt lengths on pages 10 and 11 Included drawing MROI087-02 in appendix
0.4	2009-05-20	MF	Revised MROI assembly drawing for DL pipe replaces drawing MROI087-02
0.5	2009-06-16	MF	Revised low latency cable to plenum type: p11
0.6	2010-09-17	MF	Revised inductive power cable & connector: p11 Revised appearance and cable entry of inductive power inverter.
0.7	2010-10-15	MF	Assigned pin numbers to power connectors p11

3 Notification List

The following people should be notified by email that a new version of this document has been issued:

MROI: Fernando Santoro

**MRAO: Chris Haniff
David Buscher
Martin Fisher**

Table of Contents

1	ICD Description	2
2	Change Record	2
3	Notification List	2
4	Scope	3
5	Acronyms and Abbreviations	4
6	Applicable Documents	4
7	Introduction	4
8	Requirements	5
8.1	Mechanical Interfaces	5
8.1.1	Delay Line supports to DLA slab	5
8.1.2	Delay Line anchor to DLA slab	5
8.1.3	Delay Line Pipe to DLA wall	5
8.1.4	Delay Line pipe to inner BCA wall	5
8.2	Electronic Interfaces	5
8.2.1	Delay Line Modules to DLA	5
8.2.2	Delay Line Datum facility	6
8.3	Services	6
8.4	Cabling	6
9	Design	6
9.1.1	The RF Module	7
9.1.2	The Inductive Power Module	7
9.1.3	Local DL enclosure	7
9.1.4	The Datum Switch	7
10	Defined Interfaces	10
10.1	Mechanical Interfaces	10
10.1.1	Delay Line supports to DLA slab	10
10.1.2	Delay Line anchor to DLA slab	11
10.1.3	Delay Line Pipe to DLA wall	11
10.1.4	Delay Line pipe to inner BCA wall	11
10.2	Electronic Interfaces	11
10.2.1	Delay Line Modules to DLA	11
10.2.2	Delay Line Datum facility	12
11	Appendices	13

4 Scope

This ICD relates the delay line to the BCF. This includes the mechanical interfaces between the pipe supports, including the anchors, and the DLA slab; the pipes and the walls through which they pass in the BCF; the electronics to be situated in the DLA and connections to the delay line pipe but not the connections between the delay line pipe and the VME system (which is covered in the Metrology to BCF interface) nor the delay line pipe and the vacuum system which is covered in a separate ICD.

5 Acronyms and Abbreviations

BCA	Beam Combining Area	MROI	Magdalena Ridge Observatory Interferometer
BCF	Beam Combining Facility	MRAO	Mullard Radio Astronomy Observatory
BRS	Beam Relay System	NMT	New Mexico Tech
DL	Delay Line	OPD	Optical Path Delay
DLA	Delay Line Area		
ICD	Interface Control Document		
ICS	Interferometer Control System		

6 Applicable Documents.

AD1 Delay Line Pipes & Supports Design Description v1.0 (INT-406-VEN-0115)

AD2 Anchor bolt specification and installation documents

DRAWINGS

AD3 Drawing of interface detail for support leg to slab (template of hole centres).

AD4 Drawing of interface detail for anchor to slab (template of hole centres).

AD5 Drawing of support and anchor locations on floor slab. MROI Infrastructure - BCF

AD6 Cabling Schematics.

REFERENCE DOCUMENTS

RD1 Delay line to Beam Relay system (INT-406-VEN-0008)

RD2 Delay line to metrology system (INT-406-VEN-0010)

RD3 Metrology System to BCF (INT-406-VEN-0012)

RD4 Metrology System to Beam Relay System (INT-406-VEN-0013)

RD5 Anchor Requirements for Delay Line Supports

RD6 Drawings: Delay line supports and anchor.

RD7 Proposed Delay Line Tools, Jigs and Handling Procedures (INT-406-VEN-0119)

7 Introduction

The delay lines are mounted on support frames which are fixed to the delay line slab in the DLA using chemical anchor bolts. The supports are fitted at locations where the pipes are joined and a special support, called an anchor is, is located near to the BCA end of the DLA on a specially thickened part of the floor slab. The anchor restrains the delay line in the longitudinal directions and therefore must be capable of taking substantial load in that direction.

In order for the delay line pipe sections to be correctly installed and aligned the holes for the bolt locations for the supports and the anchor must be accurately surveyed, marked and then drilled into the concrete slab. This document provides the necessary details for the location of holes for the delay line supports and the anchors. Drawings are provided from which drilling templates may be manufactured. The location of support points depend on the length of pipe sections to be fitted but the majority of pipes are standard lengths of 12 feet. Also, the exact centreline for each delay line

must be determined before the holes for the supports can be referenced to it. Positions for the hole locations starting from the metrology end of the delay line are given in the assembly drawing included in the appendices.

The delay line pipes pass through the DLA/BCA wall and inner BCA wall in slots which have been incorporated when the structure was built. The interface with these slots is to be light-tight, have good thermal properties yet minimise the transmission of vibrations.

The delay lines also require signals and services that are to be provided by electronics placed in racks or enclosures situated at locations in the DLA. The details of those connections are provided here, together with the requirements and interfaces for the racks.

8 Requirements

8.1 Mechanical Interfaces

8.1.1 Delay Line supports to DLA slab

Each delay line support is required to be connected to the DLA floor slab by four anchor bolts which project from the concrete through oversized holes in the support base. These anchor bolts are to be of sufficient length to allow the height of each support to be adjusted so that the delay line pipe is optimally adjusted with reference to the nominal incoming beam axis. Adjustment of the lateral position of the pipe can be undertaken at the support base, using the oversize holes or by applying a small tilt to the base.

8.1.2 Delay Line anchor to DLA slab

The delay line anchor requires larger diameter anchor fixings and many more than with a support; it is also to be grouted to the floor to provide a stronger connection. The anchor bolts must be long enough to allow for sufficient grout thickness between the anchor and the floor, taking into account any unevenness in the floor slab or fabrication error in the anchor frame.

8.1.3 Delay Line Pipe to DLA wall

The delay line pipes must pass through the wall of the DLA into the outer BCA area without undue coupling of vibration. A slot has been incorporated into the design of the building to allow for this. At some stage the gap between the delay line pipes and the wall must be filled to provide a thermal barrier and also be light tight. The material or structure used to fill the gap must be capable of being removed for the purposes of future re-alignment of the delay line should it become necessary.

8.1.4 Delay Line pipe to inner BCA wall

The delay line pipes must pass through the wall of the BCA into the inner BCA area without undue coupling of vibration. A similar arrangement to that provided in 8.1.3 is to be made.

8.2 Electronic Interfaces

8.2.1 Delay Line Modules to DLA

At the 'far' end of each delay line there are two modules, the RF module and the inductive power (IP) module, mounted on the end plate. The RF module accepts two cables directly from the DLA and 5V power from a local source. One of the cables is a standard network connection and the other is a screened twisted pair carrying the low-latency signal from the VME System located in the outer BCA. The IP module requires 48V power from a local source. A small enclosure (referred to as a local DL enclosure) should be mounted at the foot of each delay line to house power supplies which provide 5V and 48V to the modules mounted on

the end-plate of the delay line. Utility power should be fed to each local DL enclosure.

8.2.2 Delay Line Datum facility

The datum facility is an optical switch mounted close to the anchor position on each delay line. The switch must be electrically isolated from the DL pipe but the cable screened and grounded at the VME System. Each datum switch shall be separately connected to the appropriate channel of the custom circuit board in the VME system which is located in the outer BCA.

8.3 Services

The following services are required for each delay line and are listed together with other cabling requirements.

- Utility power: to be supplied to each local DL enclosure.
- Network: to be supplied to each DL RF module

Because delay lines will initially be of different lengths it may be necessary to provide power cabling from different points along the length of the DLA.

Network connections could all come from the far end of the DLA if it is preferred that all switches are located in one position.

8.4 Cabling

The cabling required to be routed to each delay line is listed in Table 1 below. In this table 'n' refers to the delay line number. The suggested cabling arrangement for handling different lengths of delay line is shown in Figure 2.

Table 1 Delay line cabling required in the DLA (n is the delay line number)

Cable	From	To
Low latency analogue signal n	VME System (BCF)	DL n RF module
Datum signal and power n	VME System (BCF)	DL n datum switch
Network n	Network outlet	DL n RF module
Power supply for RF module	Local DL enclosure n	DL n RF module
Power supply for inductive power (IP) module	Local DL enclosure n	DL n IP module
Utility power	Utility power circuit	DL n local enclosure

9 Design

At the 'far' end of each delay line there are three electrical connections to the pipe, each with low voltage power supply requirements. For each delay line, two RF signals and one inductive power signal are injected into the pipe from modules mounted on the pipe end plate. The RF module houses both the network RF transceiver (wi-fi access point) and the low latency RF transmitter link. The inductive power module houses the inductive power inverter circuitry. A diagram of the connections at the end of each delay line is shown in Figure 1.

9.1.1 The RF Module.

This module houses a commercially available 'wireless access point' unit to provide network communication to the trolley and a custom designed circuit to launch the low latency signal over a modulated RF transmission.

The network input is obtained from a network switch located in the DLA (probably at the far end). The network cable passes through a hole in the RF module to plug directly into wireless access point unit inside. The output signal from the wireless access point unit is fed through a hole in the RF module and plugs into a feed-through connector on the pipe end plate which is connected to an aerial mounted internally. The module requires 5V power (shared it with the low latency link module) which is provided by the power supply unit in the local DL enclosure

The low latency cable from the VME system located in the outer BCA plugs directly into the RF module via a LEMO type connector. Internally this connects to the low-latency circuit housed in a box within the RF Module. The circuit accepts the differential analogue signal over a twisted pair cable from the VME system and converts it to modulated RF. The RF signal passes through a hole in the RF Module and plugs into a connector on the pipe end plate which connects to another aerial mounted internally.

9.1.2 The Inductive Power Module.

This module houses an inverter which operates at about 22kHz and supplies approximately 2A at nominally 40V to the primary circuit i.e. the wire running down the inside of the pipe with the return path being the pipe itself. The output of the module connects to a feed-through connector mounted in the end plate. The IP module requires a 48V 5A power supply which should be mounted in an enclosure reasonably close by. An enclosure situated the foot of the far end of each delay line is the best arrangement.

9.1.3 Local DL enclosure

This enclosure will have utility power fed to it to provide for the power supplies and also local outlets for extra lighting, soldering iron or test equipment. A suitable 48V power supply unit for the inductive power supply is the Altech PSP-24048 which is DIN rail mounting and a suitable 5V power supply is the IDEC PS5R-SB05 which is also DIN rail mounting. Both supplies are fan-less. Data sheets for these supplies are included in the appendix.

9.1.4 The Datum Switch

The datum switch is mounted in an assembly inserted into the delay line pipe close to the anchor position. It is electrically isolated from the pipe and comes with a connector pre-wired with a 2m lead with tails. This lead is to be discarded and a connector supplied which allows a long cable to be connected directly from the custom board in the DL VME System located in the outer BCA to the datum switch.

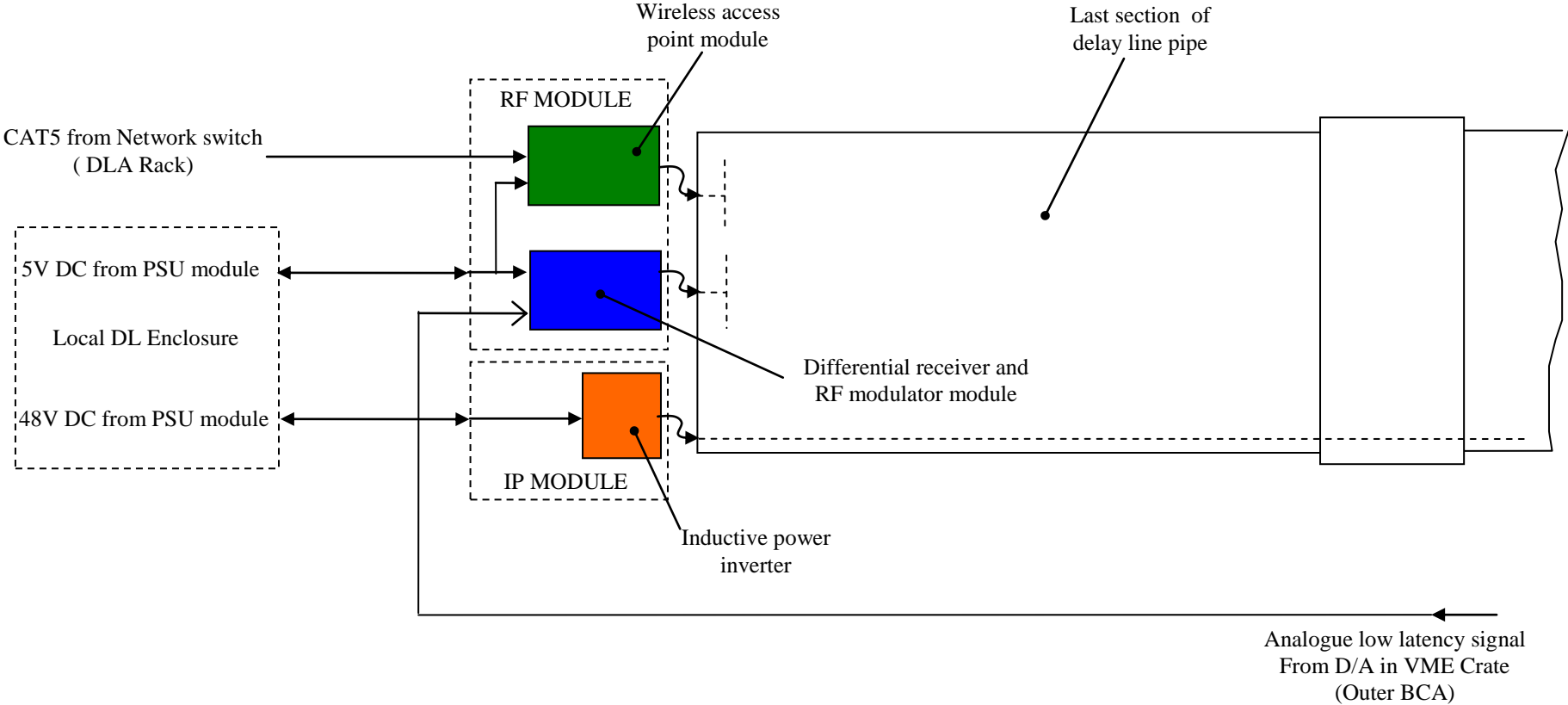

Figure 1 Modules located at the far end of each delay line.

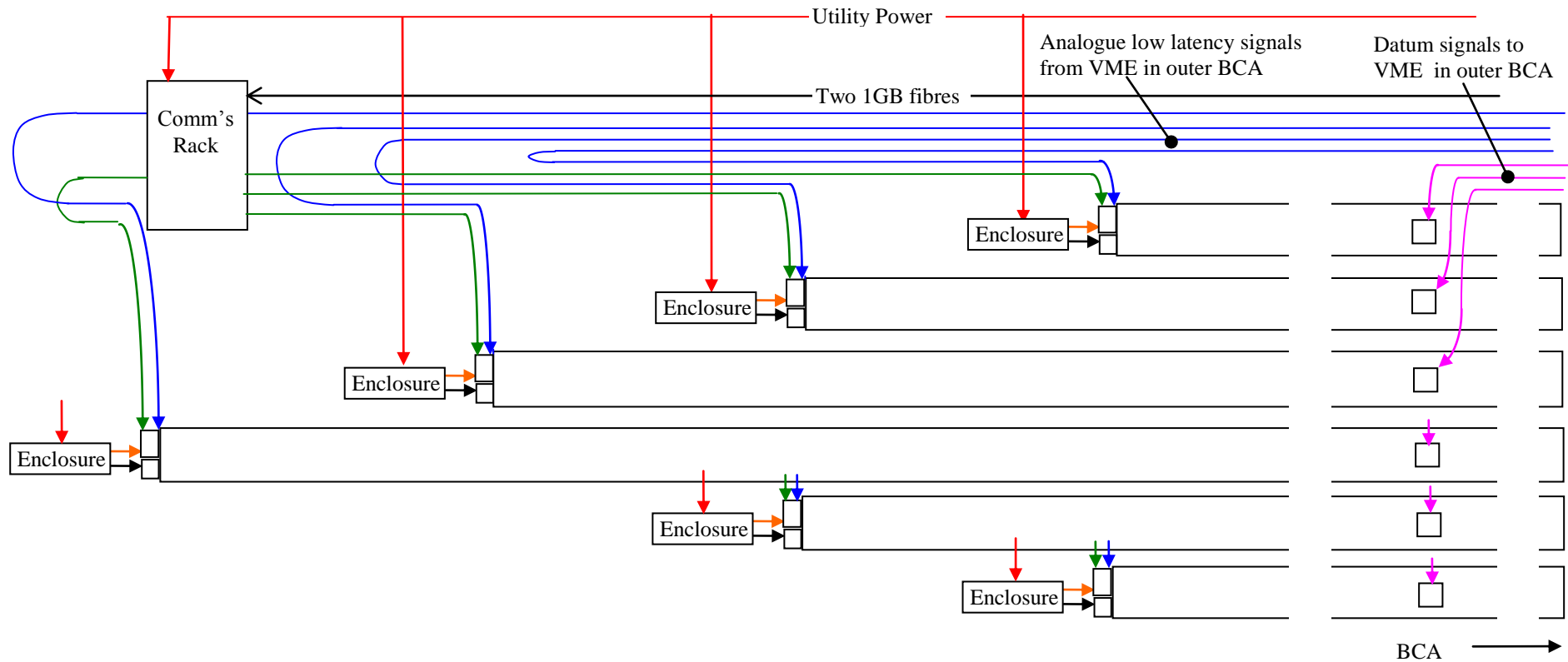

Figure 2 A possible arrangement of cabling for delay lines of different length from 30m to 190m. The analogue low latency cables are full length but pulled back to the appropriate delay line. The network cable between the delay line and the switch should not be longer than 100m and so should be located in a rack in an intermediate position along the DLA and connected to a separate shorter 1GB fibre. The 48V and 5VDC power supplies should be in enclosures at the end of each delay line. The datum signal cables are connected to boxes mounted on the anchor of each delay line. (Note that not all the cables are shown for clarity of the drawing but it is expected that cables will route down one side of the DLA and into the outer BCA close to the DL Electronics rack which houses the VME system.)

10 Defined Interfaces

10.1 Mechanical Interfaces

10.1.1 Delay Line supports to DLA slab

Each delay line support is required to be connected to the DLA floor slab by four anchor bolts which project from the concrete through oversized holes in the support base. These anchor bolts are to be of sufficient length to allow the height of each support to be adjusted so that the delay line pipe is optimally adjusted with reference to the nominal incoming beam axis. The offset of the support base from the floor of the DLA must not exceed 45mm and so, to accommodate variation in the level of the DLA slab, two support base types are defined with the only difference being the height of the attachments for the legs of the support (see Figure 3. The appropriate support base should be used so that the offset referred to above is not exceeded. Adjustment of the lateral position of the pipe can be undertaken at the support base, using the oversize holes or by applying a small tilt to the base.

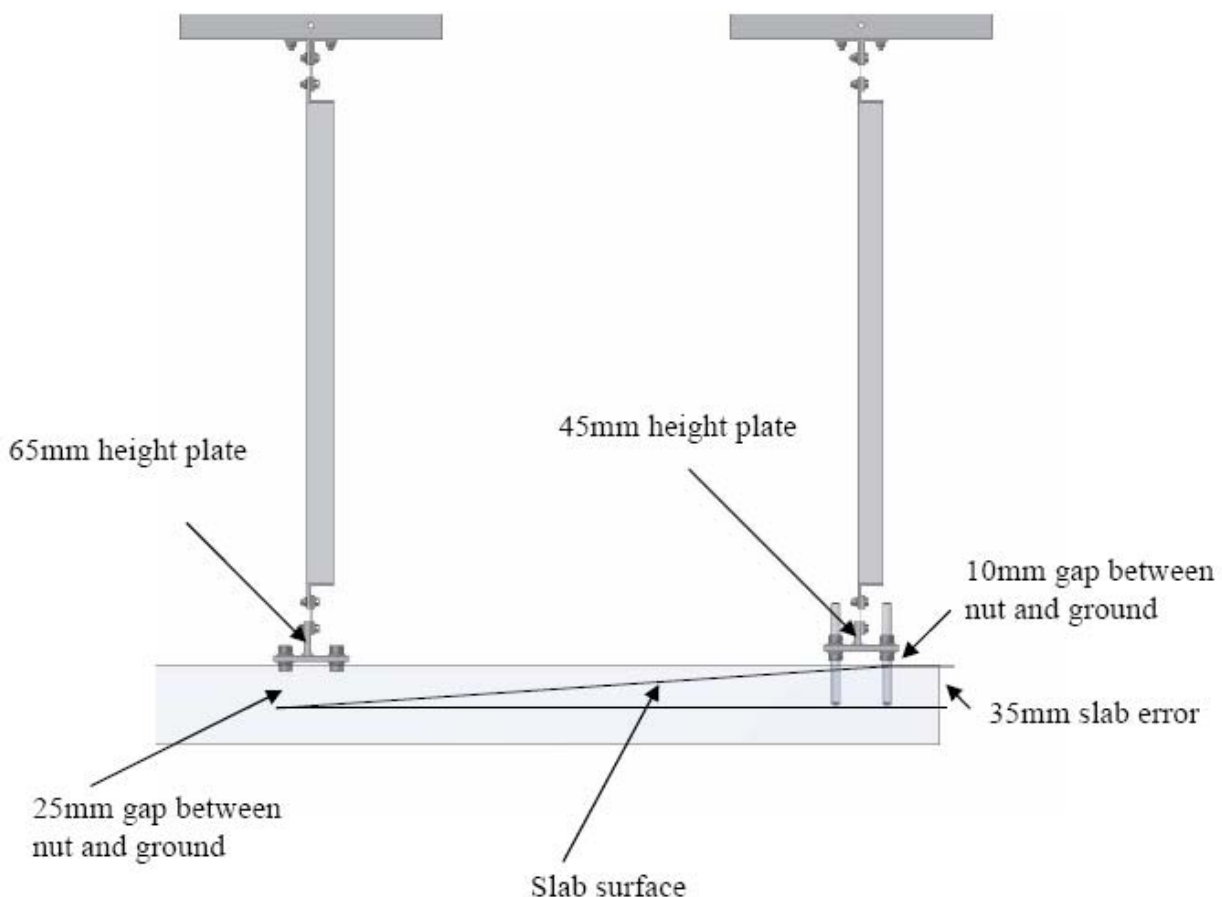

Figure 3 The use of two types of support plate with different heights to accommodate the variation in level of the DLA floor.

The interface with the DLA floor is the hole-pattern of the support base. The dimensions for the hole-pattern are given by drawing MROI-072. A pdf copy of this drawing is included in the appendix.

The appropriate anchor bolt for the DL supports is: HILTI type 5/8" ASTM A 193 B7 6 3/4" or equivalent, using an embedment depth of 4" (101.6mm), see drawing MROI 087-02 also given in the appendix.

10.1.2 Delay Line anchor to DLA slab

The delay line anchor requires larger diameter anchor fixings and many more than with a support; it is also to be grouted to the floor to provide a stronger connection. The anchor bolts must be long enough to allow for sufficient grout thickness between the anchor and the floor, taking into account any unevenness in the floor slab or fabrication error in the anchor frame.

The interface with the DLA floor is the hole-pattern of the anchor base. The dimensions for the hole-pattern are given by drawing MROI-078-02. A pdf copy of this drawing is included in the appendix.

The appropriate anchor bolt for the DL anchor is: HILTI type ¾” ASTM A193 B7 9 ½” or equivalent, using an embedment depth of 6-3/4” (171.5mm) drawing MROI 087-02 also given in the appendix. The torque on the studs for clamping the nuts should not be larger than 54Nm.

10.1.3 Delay Line Pipe to DLA wall

The delay line pipes must pass through the wall of the DLA into the outer BCA area without undue coupling of vibration, must provide a thermal barrier and also be light tight. The material or structure used to fill the gap must be capable of being removed for the purposes of future re-alignment of the delay line should it become necessary.

10.1.4 Delay Line pipe to inner BCA wall

The delay line pipes must pass through the wall of the BCA into the inner BCA area without undue coupling of vibration. A similar arrangement to that provided in 8.1.3 is to be made.

10.2 Electronic Interfaces

10.2.1 Delay Line Modules to DLA

The RF module accepts two cables directly from the DLA and 5V power from a local source. One of the cables is a standard network connection and the other is a screened twisted pair carrying the low-latency signal from the VME System located in the outer BCA. The IP module requires 48V power from the local DL enclosure. The position and orientation of these modules on the end plate is shown in Figure 4. The interface connections and cable types are given in Table 2. Connection details for the low-latency link cable are given in RD2.

Table 2 Interface connections, pin numbers and cable types the RF module and IP module

Cable	From [Cable connector]	To [Cable connector]	Cable type
Low latency analogue signal	VME System (BCF) [3-way Lemo 0B plug FGG.0B.303.CLAD42Z]	DL RF module * [3-way Lemo 0B plug FGG.0B.303.CLAD42Z]	2-conductor stranded, foil shielded with drain wire Belden 9451P
Network	Network outlet	DL RF module	Standard CAT5 connection
Power supply for RF module	Local DL enclosure Suggest use of same connector type as at RF module.	DL RF module [2-way Lemo 1B plug FGG.1B.302.CYCD42Z]	2-conductor cable with shield, diameter 3.1mm to 4mm Alpha Wire 58431 Pin 1 +5V Pin2 0V
Power supply for IP module	Local DL enclosure Wire terminals	DL IP module Bulgin PX 0731/P Pin L +48V Pin N 0V Pin G Gnd	~3.5m 3-conductor stranded 10A rated 1mm ² cross section or equivalent (AWG 18)

* Note: shield of cable is not to be connected at the DL end of the cable.

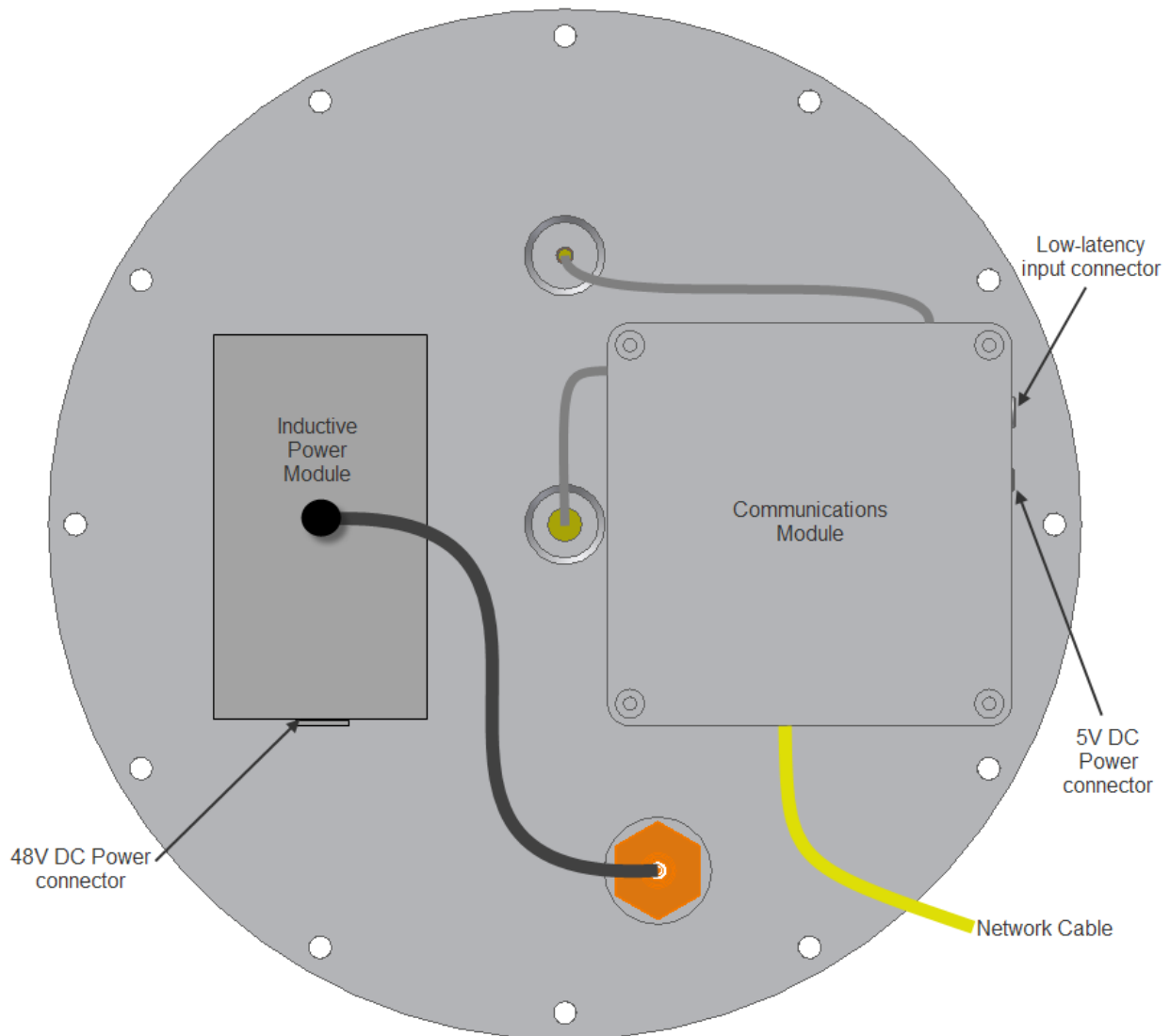

Figure 4 Arrangement of modules on the end plate of the delay line showing interface connections. The Inductive Power Module is representative only as the box for this is yet to be chosen so that it can accommodate a local reset switch. The two aerial connections leave the Communications Module through holes as does the network cable as these have connectors internally. The two connectors for the communications module are specified in Table 2.

10.2.2 Delay Line Datum facility

The datum facility is an optical switch mounted close to the anchor position on each delay line. The switch must be electrically isolated from the DL pipe but the cable screened and grounded at the VME System. Each datum switch shall be separately connected to the appropriate channel of the custom circuit board in the VME system which is located in the outer BCA. Connection details are given in RD2.

Cable	From [Cable connector]	To [Cable connector]	Cable type
Datum signal and power	VME System (BCF) [5-way Lemo 0B plug FGG.0B.305.CLAD42Z]	DL datum switch [Harting Harax M12 female plug part 21 03 221 2405]	4-conductor stranded, shielded diameter 3.1mm to 3.4mm Alpha Wire 57004

11 Appendices

Page 1 – MROI Infrastructure: location and assembly of DL pipes close to the BCA

Page 2 – Assembly drawing of pipe support for fixing hole pattern

Page 3 – Anchor support assembly for fixing hole pattern

Page 4 – Altech PSP240 48V DC power supply specification sheet

Page 6 – IDEC PS5R-S 5V DC power supply specification sheet

REVISION			
ZONELTR	DESCRIPTION	DATE	BY APVD
01			

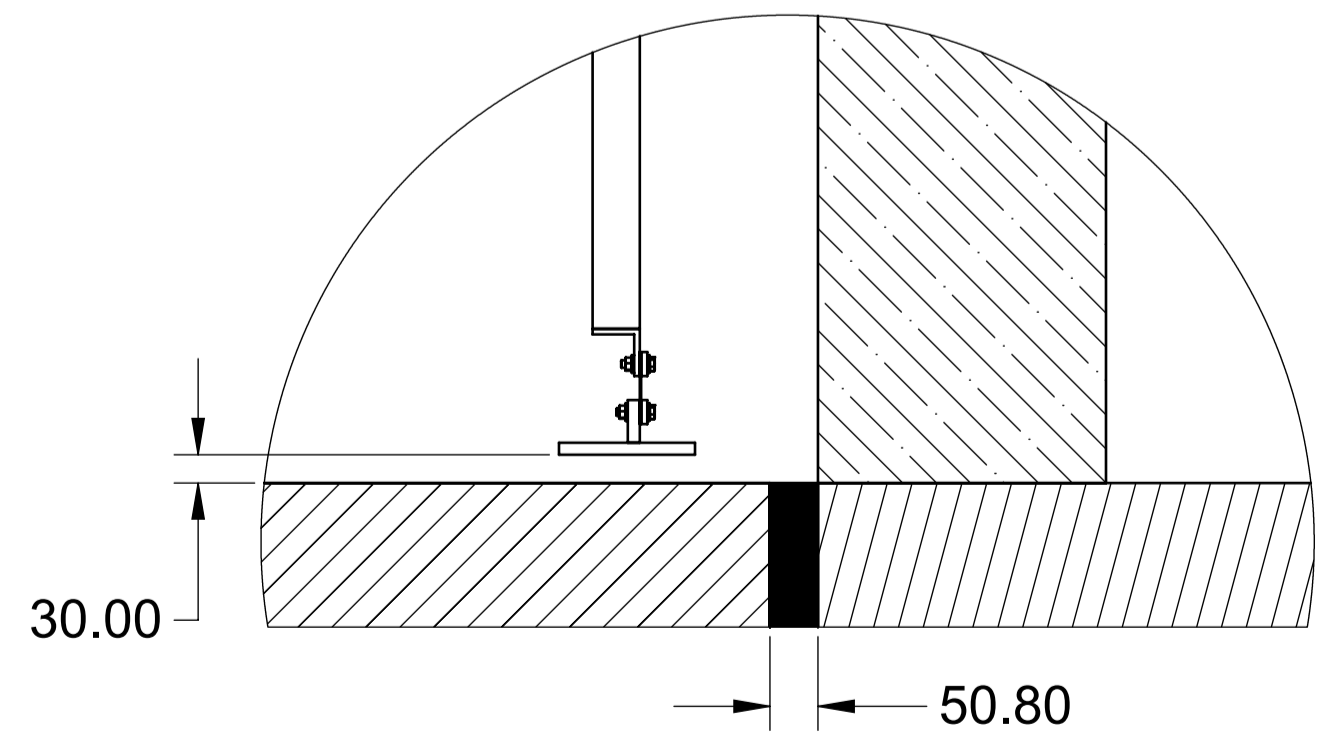
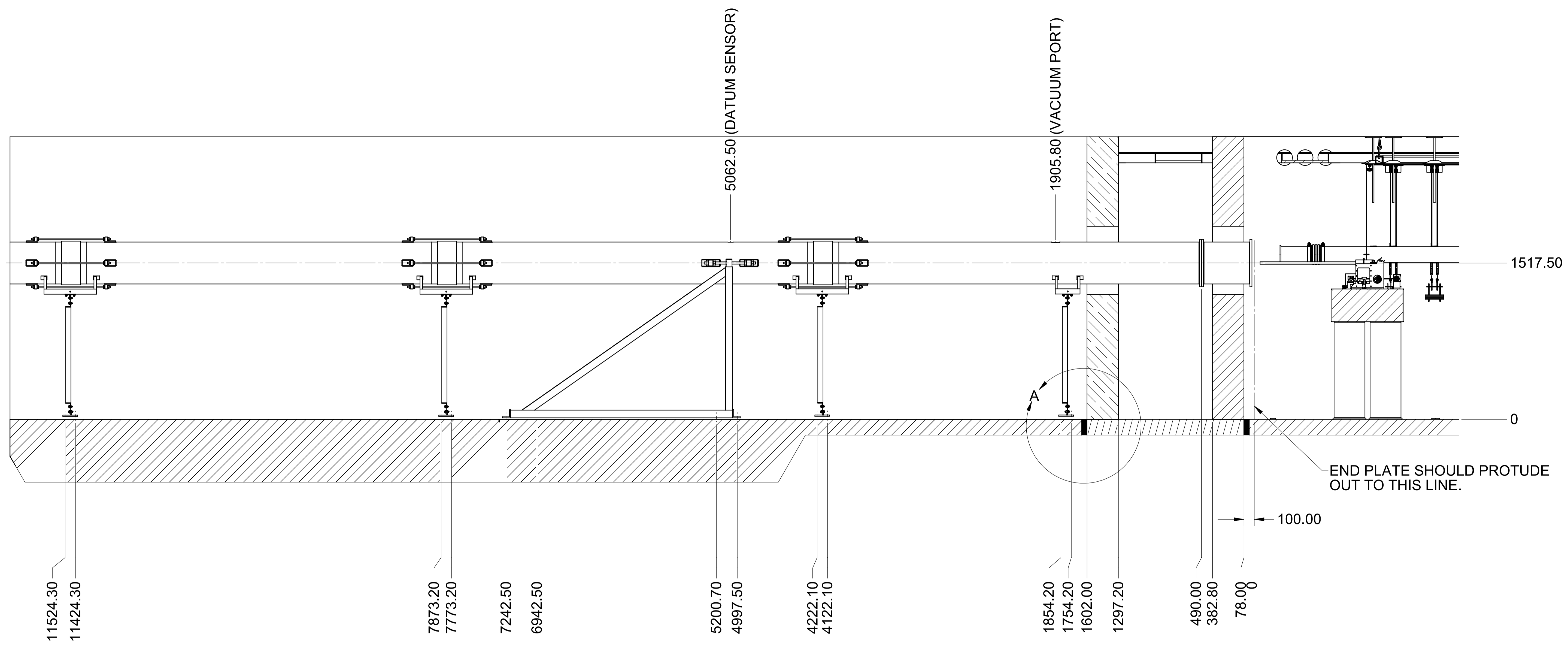

DETAIL A
SCALE 1 : 8

TOLERANCES UNLESS OTHERWISE NOTED		 New Mexico Institute of Mining and Technology MAGDALENA RIDGE OBSERVATORY INTERFEROMETER	
NOTES: UNLESS OTHERWISE NOTED: 1. DIMENSION LIMITS AFTER PLATING 2. DIMENSIONS ARE IN MILLIMETERS (mm) 3. REMOVE ALL BURRS AND SHARP EDGES 4. MACHINED SURFACE ROUGHNESS: 3.2um Ra 5. FINISH: - 6. QTY: 1 7. MAT'L: See Part List		USED ON SYSTEM INTERFEROMETER SUB-SYSTEM DELAY LINE SYSTEM NEXT-ASSY -	NAME MROI INFRASTRUCTURE - BCF
DESIGNED BY MRQ	DATE -	APPROVED BY -	DATE -
DRAWN BY CS	DATE 05/20/09	APPROVED BY Mox20x	DATE Mox20x
CHECKED BY -	DATE -	APPROVED BY Mox20x	DATE Mox20x
SIZE D	DWG NO. MROI INFRASTRUCTURE	REV -	
SCALE 1 : 15	CAD FILE: MROI INFRASTRUCTURE.SLDDWR	SHEET 1 / 1	

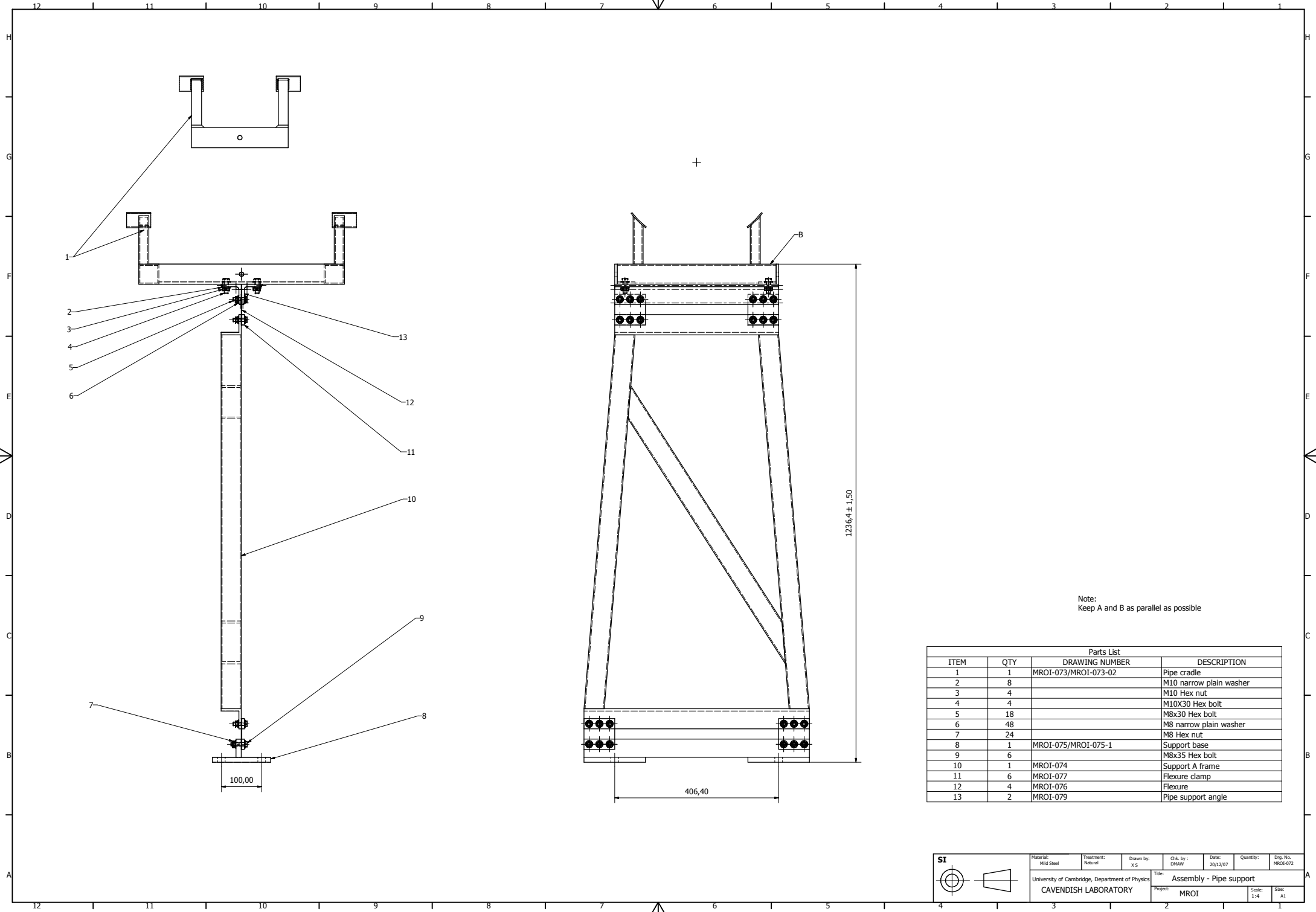

Note:
Keep A and B as parallel as possible

Parts List			
ITEM	QTY	DRAWING NUMBER	DESCRIPTION
1	1	MROI-073/MROI-073-02	Pipe cradle
2	8		M10 narrow plain washer
3	4		M10 Hex nut
4	4		M10X30 Hex bolt
5	18		M8x30 Hex bolt
6	48		M8 narrow plain washer
7	24		M8 Hex nut
8	1	MROI-075/MROI-075-1	Support base
9	6		M8x35 Hex bolt
10	1	MROI-074	Support A frame
11	6	MROI-077	Flexure clamp
12	4	MROI-076	Flexure
13	2	MROI-079	Pipe support angle

	Material: Mild Steel	Treatment: Natural	Drawn by: x S	Chk. by: DMAW	Date: 20/12/07	Quantity:	Dwg. No. MROI-072	
	Title: Assembly - Pipe support						Project: MROI	Scale: 1:4
	University of Cambridge, Department of Physics CAVENDISH LABORATORY						Sheet: A1	

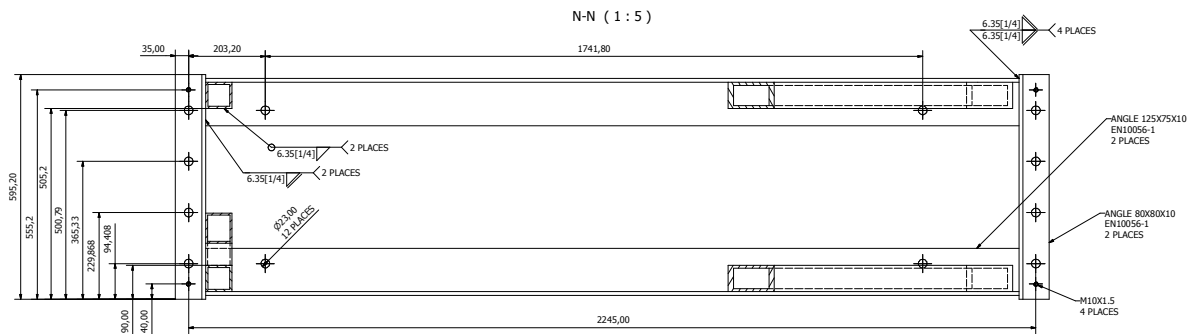
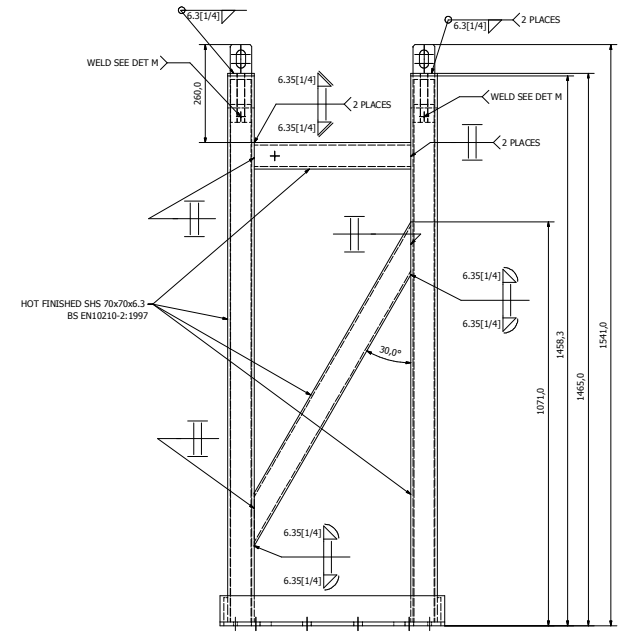
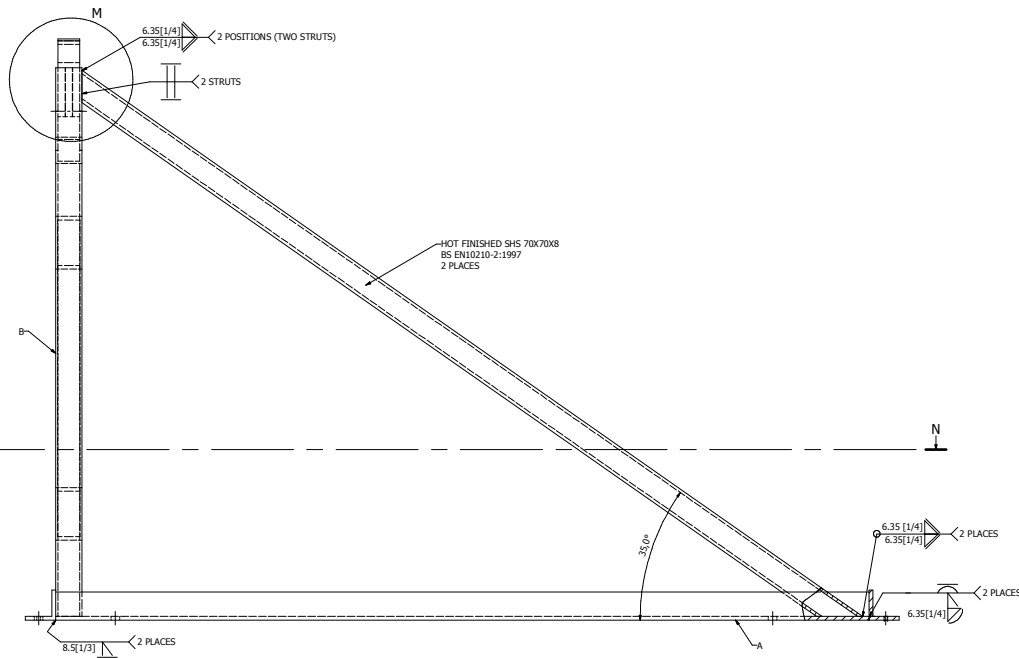
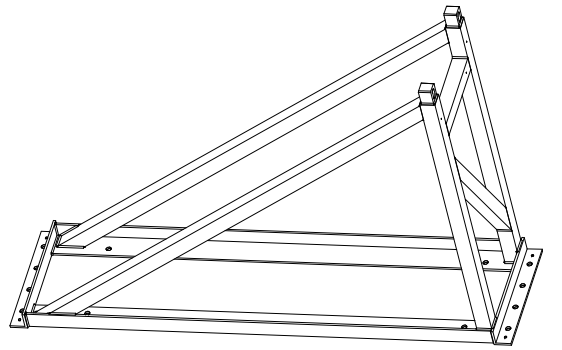
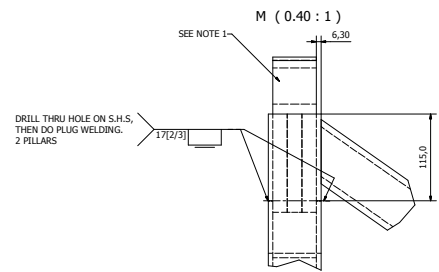
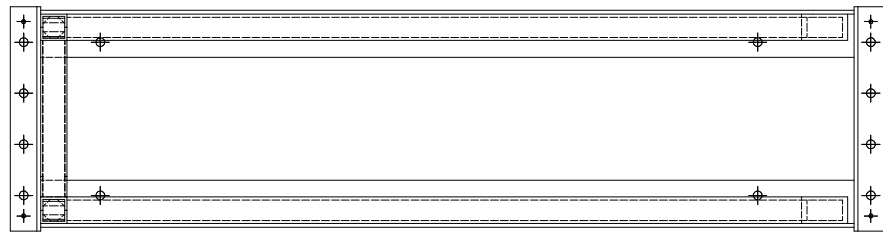

NOTES:
 1. INSERTS - SEE DRAWING NO. MROJ-081. REMOVE MATERIAL TO FIT THE HOLLOW IF NEEDED.
 2. FACE A AND B SHOULD BE AS FLAT AS POSSIBLE

	Material	Quantity	Drawn by	Date	Quantity	Drp. No.
	Steel 2 x 125x75 + 2 x 80x80 + 4 x 6.3 20mm x 6.3	1.0	6.5	02/02/2017	1.00	MROJ-081-01
University of Cambridge, Department of Physics CAVENDISH LABORATORY	Project	Anchor Support MRO		Scale	1:5	Sheet
	Person	MROJ		Scale	1:5	Sheet



■ Features :

- Universal AC input / Full range
- Built in active PFC function, P F > 0.95
- Protections: Short circuit/Over load/Over voltage/Over temperature
- Cooling by free air convection
- Can be installed on DIN rail TS-35/7.5 or 15
- UL 508 (industrial control equipment) approved
- LED indicator for power on
- 100% full load burn-in test
- Fixed switching frequency at 100KHz
- 3 years warranty



SPECIFICATION

MODEL	PSP-24024	PSP-24048	
OUTPUT	DC VOLTAGE	24V	48V
	RATED CURRENT	10A	5A
	CURRENT RANGE	0 ~ 10A	0 ~ 5A
	RATED POWER	240W	240W
	RIPPLE & NOISE (max.) Note.2	80mVp-p	150mVp-p
	VOLTAGE ADJ. RANGE	24 ~ 28V	48 ~ 53V
	VOLTAGE TOLERANCE Note.3	±1.0%	±1.0%
	LINE REGULATION	±0.5%	±0.5%
	LOAD REGULATION	±1.0%	±1.0%
SETUP, RISE, HOLD TIME	800ms, 40ms, 20ms/230VAC 800ms, 40ms, 20ms/115VAC at full load		
INPUT	VOLTAGE RANGE	85 ~ 264VAC 120 ~ 370VDC	
	FREQUENCY RANGE	47 ~ 63Hz	
	POWER FACTOR	PF>0.95/230VAC	PF>0.98/115VAC at full load
	EFFICIENCY (Typ.)	84%	85%
	AC CURRENT	3.5A/115VAC	1.8A/230VAC
	INRUSH CURRENT (max.)	COLD START 30A/115VAC	50A/230VAC
	LEAKAGE CURRENT	<3.5mA/ 240VAC	
PROTECTION	OVER LOAD	105 ~ 150% rated output power Protection type : Constant current limiting, recovers automatically after fault condition is removed	
	OVER VOLTAGE	30 ~ 36V	54 ~ 60V
	OVER TEMPERATURE	100°C ±5°C (TSW1) Detect on heat sink of power transistor Protection type : Shut down o/p voltage, recovers automatically after temperature goes down	
ENVIRONMENT	WORKING TEMP.	-10 ~ +70°C (Refer to output load derating curve)	
	WORKING HUMIDITY	20 ~ 90% RH non-condensing	
	STORAGE TEMP., HUMIDITY	-20 ~ +85°C, 10 ~ 95% RH	
	TEMP. COEFFICIENT	±0.03%/°C (0 ~ 50°C)	
	VIBRATION	10 ~ 500Hz, 2G 10min./1cycle, 60min. each along X, Y, Z axes	
SAFETY & EMC (Note 4)	SAFETY STANDARDS	UL508, UL60950-1, EN60950 Approved	
	WITHSTAND VOLTAGE	I/P-O/P:3KVAC I/P-FG:1.5KVAC O/P-FG:0.5KVAC	
	ISOLATION RESISTANCE	I/P-O/P, I/P-FG, O/P-FG:100M Ohms/500VDC	
	EMI CONDUCTION & RADIATION	Compliance to EN55011, EN55022 (CISPR22) Class B	
	HARMONIC CURRENT	Compliance to EN61000-3-2,-3	
	EMS IMMUNITY	Compliance to EN61000-4-2,3,4,5,6,8, ENV50204, EN55024, EN61000-6-2 (EN50082-2) Heavy industry level, criteria	
OTHERS	MTBF	105.5Khrs min. MIL-HDBK-217F (25°C)	
	DIMENSION	125.5*125.2*100mm (W*H*D)	
	PACKING	1.2Kg; 20pcs/14.4Kg/1.2CUFT	
NOTE	<p>1. All parameters NOT specially mentioned are measured at 230VAC input, rated load and 25°C of ambient temperature.</p> <p>2. Ripple & noise are measured at 20MHz of bandwidth by using a 1.2" twisted pair-wire terminated with a 0.1uf & 4.7uf parallel capacitor.</p> <p>3. Tolerance : includes set up tolerance, line regulation and load regulation.</p> <p>4. The power supply is considered a component which will be installed into a final equipment. The final equipment must be re-confirmed that it still meets EMC directives.</p>		

Mechanical Specification

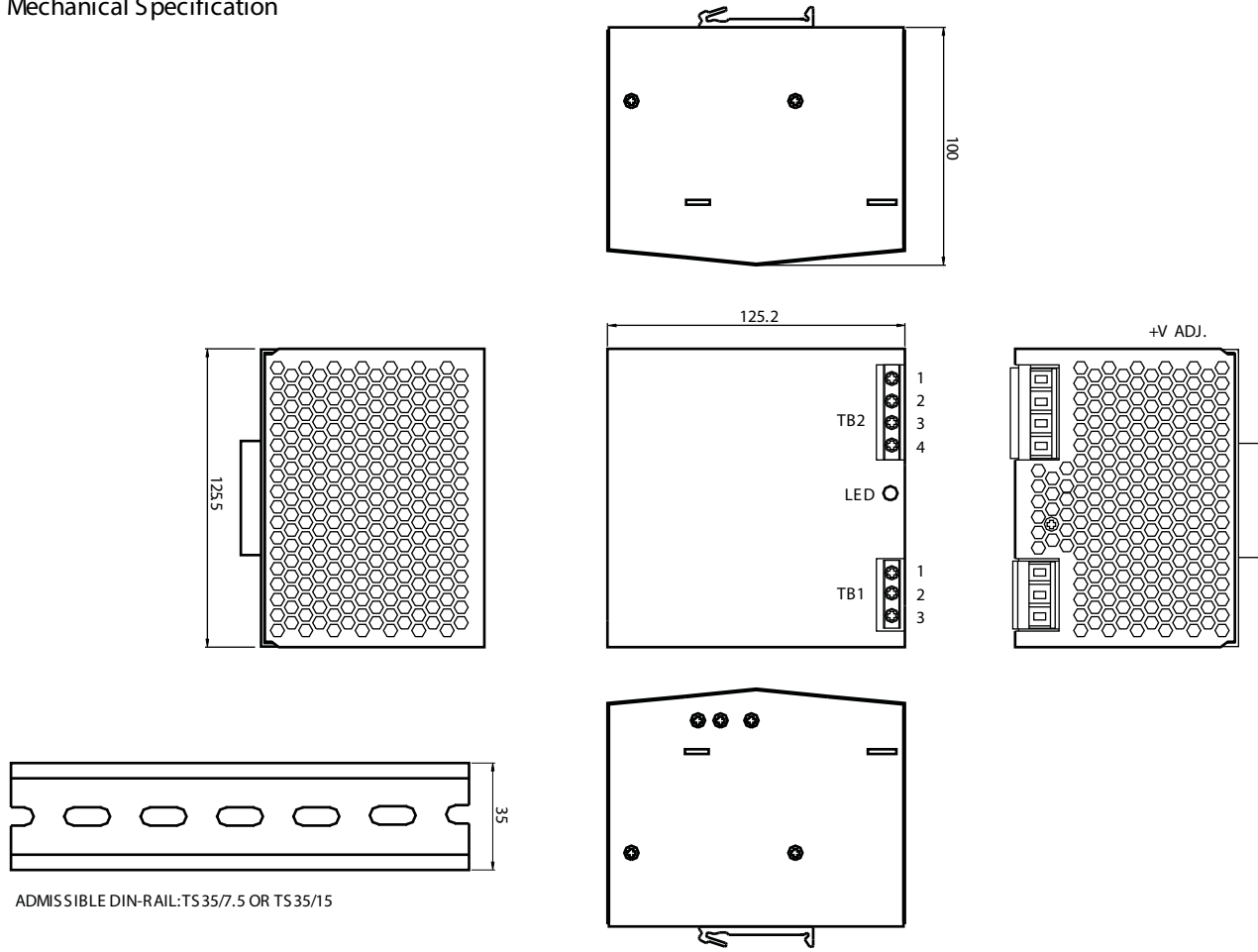

ADMISSIBLE DIN-RAIL: TS35/7.5 OR TS35/15

Terminal Pin. No Assignment (TB1)

Pin No.	Assignment
1	FG ⊕
2	AC/N
3	AC/L

Terminal Pin. No Assignment (TB2)

Pin No.	Assignment
1,2	DC OUTPUT +V
3,4	DC OUTPUT -V

Output Derating

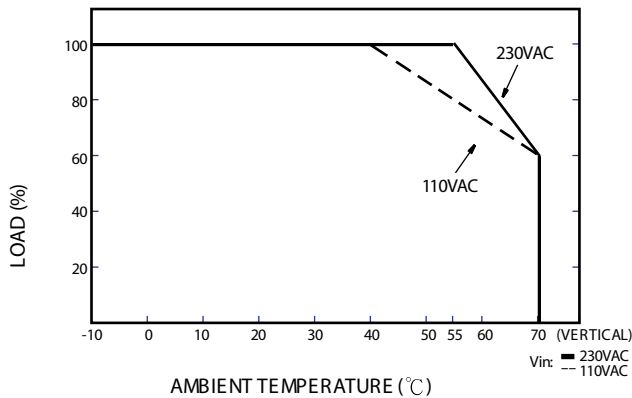

Output derating VS input voltage

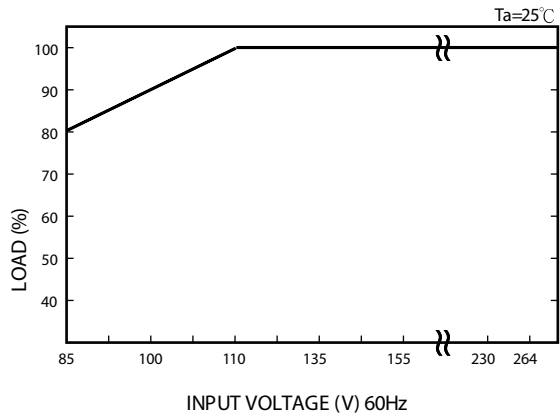



Slim Line Power Supplies PS5R-S

Features

- Lightweight and Compact in size
- Wide Power Range: 15W – 240W
- Universal Input:
 - 15W to 90W: 85-264V AC/100-370V DC
 - 120W and 240W: 85-264V AC/100-350V DC
- Power Factor Correction (EN61000-3-2) for 60W to 240W
- Meets SEMI F47 Sag Immunity (120W & 240W)
- NEC Class 2 rated (15W, 30W & 60W)
- Approved for Class 1, Div. 2 Hazardous Locations
- Fused input
- Overcurrent protection, auto-reset
- Overvoltage protection, shut down
- Spring-up Screw Terminal type, IP20
- DIN rail or Panel Surface Mount
- Approvals:
 - CE Marked, TÜV, c-UL, UL 508, UL 1310 (PS5R-SB, -SC, -SD), UL 1604, EN 50178:1997, LVD: EN60950:2000, EMC: Directive, EN61204-3:2000 (EMI: Class B, EMS: Industrial)



For more information on these and other IDEC power supplies, visit:
www.idec.com/powersupply

Specifications

Part Numbers	5V DC output	PS5R-SB05	–	–	–	–	–	
	12V DC output	PS5R-SB12	PS5R-SC12	–	–	–	–	
	24V DC output	PS5R-SB24	PS5R-SC24	PS5R-SD24	PS5R-SE24	PS5R-SF24	PS5R-SG24	
Output Capacity		15W (5V Model is 10W)	30W	60W	90W	120W	240W	
Input	Input Voltage (single-phase, 2-wire)	85 to 264 VAC, 100 to 370 VDC				85 to 264V AC, 100 to 350V DC		
	Input Current (maximum)	100VAC	0.45A	0.9A	1.7A	2.3A	1.8A	3.5A
		200VAC	0.3A	0.6A	1.0A	1.4A	1.0A	1.7A
	Internal Fuse Rating	2A	3.15A	3.15A	4A	4A	4A	6.3A
	Inrush Current (cold start)	50A maximum (at 200V AC)						
Leakage Current (at no load)	132V AC: 0.38 mA maximum 264V AC: 0.75 mA maximum		0.75mA maximum			1mA maximum		
Typical Efficiency	5V DC	69%	–	–	–	–	–	
	12V DC	75%	78%	–	–	–	–	
	24V DC	79%	80%	83%	82%	84%	–	
Output Current Ratings	5V DC	2.0A	–	–	–	–	–	
	12V DC	1.2A	2.5A	–	–	–	–	
	24V DC	0.65A	1.3A	2.5A	3.75A	5A	10A	
Voltage Adjustment	±10% (V. ADJ control on front)							
Output Holding Time	20ms minimum (at rated input and output)							
Starting Time	200ms maximum	–	–	–	–	650ms maximum	500ms maximum	
Rise Time	100ms maximum (at rated input and output)				200ms maximum			
Line Regulation	0.4% maximum							
Load Regulation	1.5% maximum					0.8% max		
Temperature Regulation	0.05% degree C maximum							
Ripple Voltage	2% peak to peak maximum (including noise)					1% peak to peak maximum (including noise)		
Overcurrent Protection	105% or more, auto reset			105 to 130%, auto reset		103 to 110%, auto reset		
Overvoltage Protection	120% min. SHUTDOWN							
Operation Indicator	LED (green)							
Voltage Low Indication	LED (amber)	–	–	–	–	LED (amber)		

Specifications Con't

	PS5R-SB	PS5R-SC	PS5R-SD	PS5R-SE	PS5R-SF	PS5R-SG	
Parallel Operation	No						
Dielectric Strength	Between Input and Ground: 2000 VAC, 1 minute*						
Insulation Resistance	Between Input & Output Terminals: 100 MΩ Min						
Operating Temperature	-10 to +65°C (14 to 149°F)					-10 to 60°C (14 to 140°F)	
Storage Temperature	-25 to 75°C (-13 to +167°F)						
Operating Humidity	20 to 90% relative humidity (no condensation)						
Vibration Resistance	Frequency 10 to 55Hz, Amplitude 0.375mm						
Shock Resistance	300m/s ² (30G) 3 times each in 6 axes						
Approvals	EMC: EN61204-3 (EMI: Class B, EMS: Industrial), c-UL (CSA 22.2 No. 14), UL 1604, UL 508, LVD: EN60950, EN50178						
	UL1310 Class 2, c-UL (CSA 22.2 No. 213 and 223)			-	SEMI F47		
Harmonic Directive	N/A			EN61000-3-2 A14 class A			
Weight (approx.)	160g	250g	285g	440g	630g	1000g	
Terminal Screw	M3.5 slotted-Phillips head screw (screw terminal type)						
IP protection	IP20 fingersafe						
Dimensions H x W x D (mm)	90 x 22.5 x 95	95 x 36 x 108		115 x 46 x 121	115 x 50 x 129	125 x 80 x 149.5	
Dimensions H x W x D (inches)	3.54 x 0.89 x 3.74	3.74 x 1.42 x 4.25		4.53 x 1.81 x 4.76	4.53 x 1.97 x 5.08	4.92 x 3.15 x 5.89	

* Between input and output: 3000VAC, 1 minute; Between output and ground: 500VAC, 1 minute

Dimensions

PS5R-SB

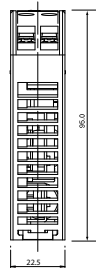
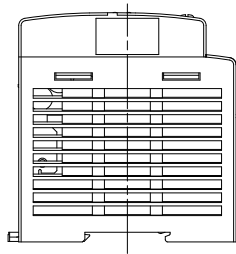
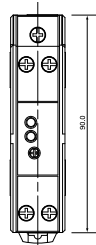

PS5R-SC
PS5R-SD

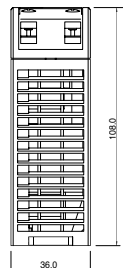
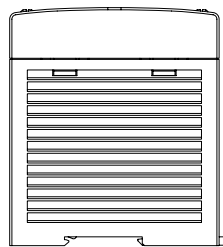
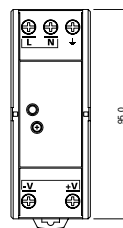

PS5R-SE

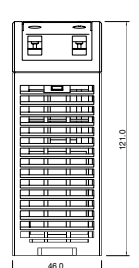
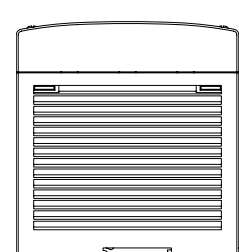
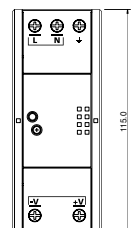

PS5R-SF

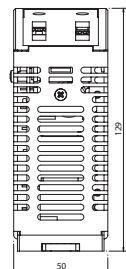
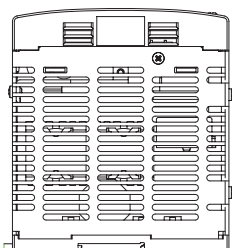
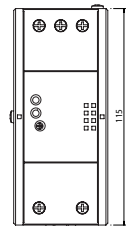

PS5R-SG

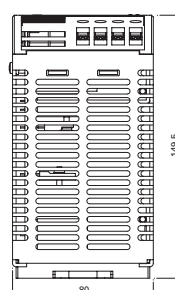
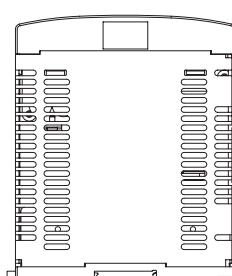
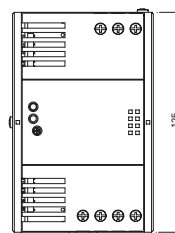

IDEC Corporation
 1175 Elko Drive Sunnyvale, CA 94089
 800-262-IDEC (4332) Fax: 408-745-5258
www.idec.com

©2007 IDEC Corporation. All Rights Reserved.
 Catalog No. PS9V-DS100-0 04/07 10K